

PLAN

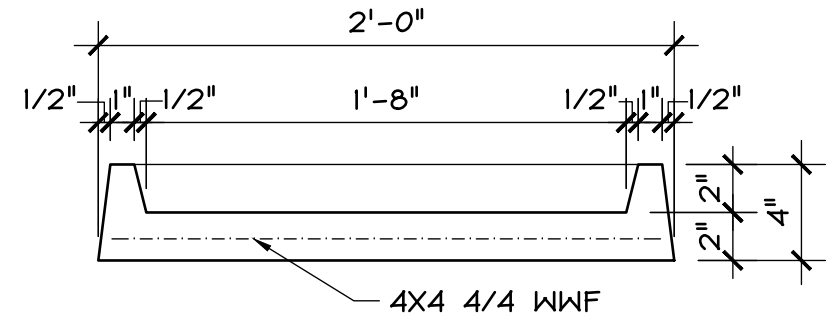

ELEVATION

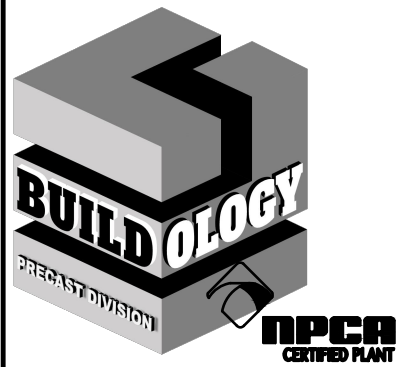

SHEET NOTES:

1. CONCRETE SPECIFICATIONS
 - 1.1. 5000 PSI COMPRESSIVE STRENGTH @ 28 DAYS
 - 1.2. 5%-8% ENTRAINED AIR
 - 1.3. POLYPROPYLENE FIBER
2. REINFORCING SPECIFICATIONS
 - 2.1. REBAR TO MEET ASTM A615, GRADE 60
 - 2.2. WELDED WIRE MESH TO MEET ASTM A1064
3. COLOR AND FINISH
 - 3.1. COLOR: GREY
 - 3.2. FINISH: SMOOTH AS CAST
 - 3.3. SEALER: VOCOMP 20

SB2432 BENCH NOTES:

1. APPROXIMATE WEIGHT
 - 1.1. 160LBS
2. CONCRETE VOLUME
 - 2.1. 0.041 CUBIC YARDS

SHEET TITLE: DIMENSION DETAIL
PRODUCT: 24X32 SPLASH BLOCK
LOCATION:
CONTRACTOR:
ARCHITECT:
DATE:
SCALE: 1 1/2"=1'-0"
SHEET NO.: 1.0