

PLAN

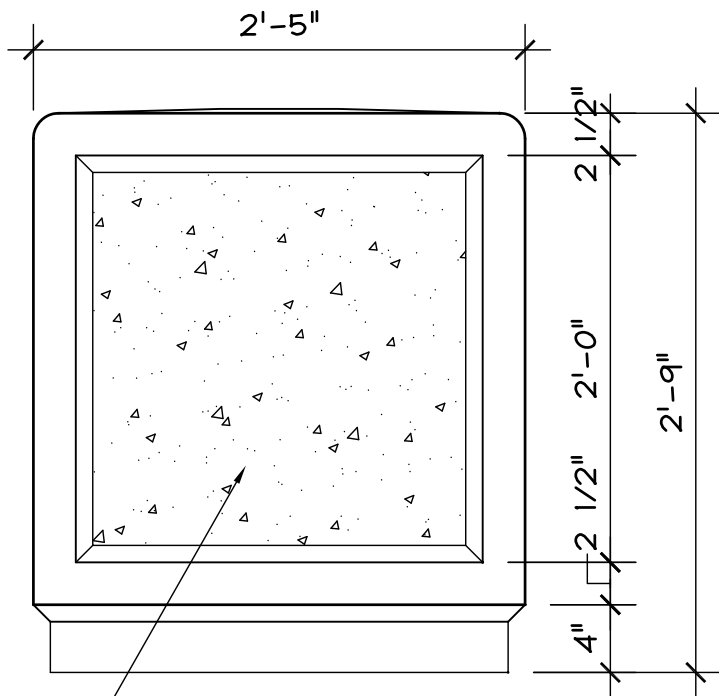

EXPOSED AGGREGATE
ALL 4 SIDES

ELEVATION

FIBERGLASS HOOD
W/ 7" ϕ OPENING

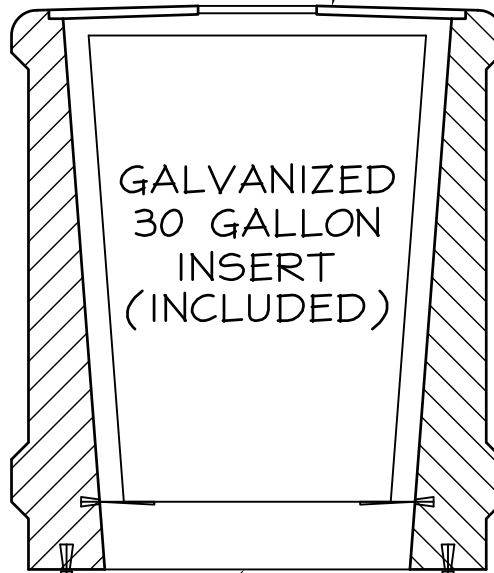

BOTTOM OPEN
FOR DRAINAGE

LEVELING
BOLTS

SECTION

WEIGHT: 1070#

CONCRETE SPECIFICATIONS

4000 f'c 28-DAY COMPRESSIVE
STRENGTH
4-7% ENTRAINED AIR

POLYPROPYLENE FIBER REINFORCING
REINFORCING

FORMS

SMOOTH SURFACE FIBERGLASS

COLORS

GREY OR INTEGRAL COLOR (COHILLS
COLOR PIGMENTS AVAILABLE)

STANDARD FINISH

SMOOTH UNLESS NOTED OTHERWISE
EXPOSED AGGREGATE
CLEAR SEALER

RINCONADA I
LITTER RECEPTACLE

TR-3329-I

ARCHITECTURAL PRECAST CONCRETE
MATERIALS, INC.