

BMESA PART LIST:

- | | | |
|--|--|--------------------------|
| 1. (1) BENCH TOP | 4.1. (4) IN BENCH | 9. 4X4 W4XW4 WELDED WIRE |
| 2. (2) BENCH LEGS | 4.2. (2) IN EACH LEG | FABRIC |
| 3. (2) 1/4" X 3" X 9 3/4" ATTACHMENT PLATE | 5. (4) 3/8" LOCK WASHERS | 9.1. 11" X 45" |
| 3.1. EMBEDDED IN LEGS | 6. (4) 3/8" WASHERS | |
| 4. (8) EMBEDDED 3/8" INSERTS | 7. (4) 3/8" X 1 1/4" BOLT | |
| | 8. (4) 3/8" PEDESTAL BOLT FOR LEVELING | |

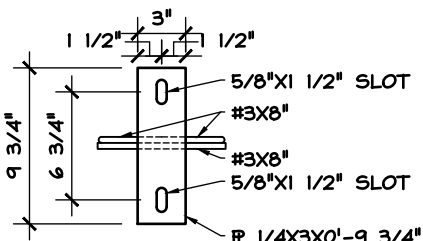

PLAN

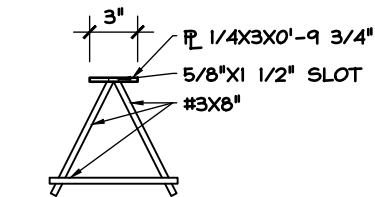

ELEVATION

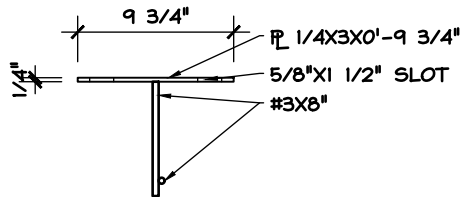

SIDE ELEVATION

ATTACHMENT PLATES

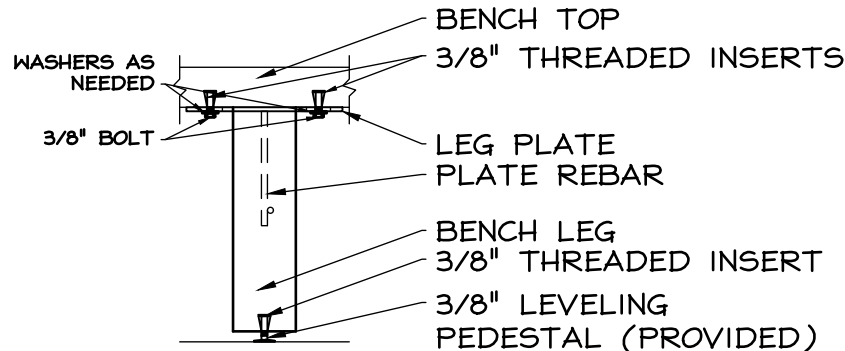

LEVELING DETAIL

SHEET NOTES:

1. CONCRETE SPECIFICATIONS
 - 1.1. 5000 PSI COMPRESSIVE STRENGTH @ 28 DAYS
 - 1.2. 5%-8% ENTRAINED AIR
 - 1.3. POLYPROPYLENE FIBER
2. REINFORCING SPECIFICATIONS
 - 2.1. REBAR TO MEET ASTM A615, GRADE 60
 - 2.2. WELDED WIRE MESH TO MEET ASTM A1064
3. COLOR OPTIONS AND FINISH
 - 3.1. GREY, WHITE, & VARIOUS COHILLS COLORS
 - 3.2. BENCH TOP- SMOOTH, LEGS- EXPOSED AGG
 - 3.3. SEALER: VOCOMP 20

MESA BENCH NOTES:

1. APPROXIMATE WEIGHT
 - 1.1. 235 LBS
2. CONCRETE VOLUME
 - 2.1. 0.060 CUBIC YARDS

SHEET TITLE: INSTALL DETAILS

PRODUCT: MESA BENCH

LOCATION:

CONTRACTOR:

ARCHITECT:

DATE:

SCALE: 3/4"=1'-0"

SHEET NO.: 2.0

